

# OWNER'S GUIDE

• ASSEMBLY • OPERATION • MAINTENANCE • PARTS •



## 19" ROTARY MOWER

### Model Number 112-380R000

### EXPORT

#### IMPORTANT!

Record the **Model No.** and **Mfg. Code** which appear on your unit in the space below. You **must** have these numbers, along with the date of purchase, in order to receive warranty or service.

**MEETS ANSI SAFETY STANDARDS**

**MODEL NO.**

**MFG. CODE**

**Important:  
Read Safety Rules  
and Instructions Carefully**



Made  
in  
AMERICA

**WARNING:** This unit is equipped with an internal combustion engine and should not be used on or near any unimproved forest-covered, brush-covered or grass-covered land unless the engine's exhaust system is equipped with a spark arrester meeting applicable local or state laws (if any). If a spark arrester is used, it should be maintained in effective working order by the operator.

In the State of California the above is required by law (Section 4442 of the California Public Resources Code). Other states may have similar laws. Federal laws apply on federal lands. A spark arrester for the muffler is available through your nearest engine authorized service dealer or contact the service department, P.O. Box 360900, Cleveland, Ohio 44136.

# IMPORTANT

## SAFE OPERATION PRACTICES



THIS SYMBOL POINTS OUT IMPORTANT SAFETY INSTRUCTIONS WHICH, IF NOT FOLLOWED, COULD ENDANGER THE PERSONAL SAFETY AND/OR PROPERTY OF YOURSELF AND OTHERS. READ AND FOLLOW ALL INSTRUCTIONS IN THIS MANUAL BEFORE ATTEMPTING TO OPERATE YOUR LAWN MOWER. FAILURE TO COMPLY WITH THESE INSTRUCTIONS MAY RESULT IN PERSONAL INJURY. WHEN YOU SEE THIS SYMBOL—  HEED ITS WARNING.



### DANGER:

Your lawn mower was built to be operated according to the rules for safe operation in this manual. As with any type of power equipment, carelessness or error on the part of the operator can result in serious injury. If you violate any of these rules, you may cause serious injury to yourself or others.



### TRAINING

1. Read this owner's guide carefully in its entirety before attempting to assemble or operate this machine. Be completely familiar with the controls and the proper use of this machine before operating it. Keep this manual in a safe place for future and regular reference and for ordering replacement parts.
2. Your rotary mower is a precision piece of power equipment, not a plaything. Therefore, exercise extreme caution at all times.
3. Never allow children to operate a power mower. Only persons well acquainted with these rules of safe operation should be allowed to use your mower.
4. Keep the area of operation clear of all persons, particularly small children and pets. Stop engine when they are in the vicinity of your mower to help prevent blade contact or thrown object injury. Although the area of operation should be completely cleared of foreign objects, an object may have been overlooked and could be accidentally thrown by the mower in any direction and cause serious personal injury to the operator or any others allowed in the area.



### PREPARATION

1. Thoroughly inspect the area where the equipment is to be used. Remove all stones, sticks, wire, bones and other foreign objects which could be picked up and thrown by the mower in any direction and cause serious personal injury to the operator or any others allowed in the area.
2. Always wear safety glasses or eye shields during operation or while performing an adjustment or repair, to protect eyes from foreign objects that may be thrown from the machine in any direction.
3. Wear sturdy, rough-soled work shoes and close-fitting slacks and shirts to avoid entanglement in the moving parts. Never operate a unit in bare feet, sandals, or sneakers.
4. Check the fuel before starting the engine. Gasoline is an extremely flammable fuel. Do not fill the gasoline tank indoors, while the engine is running, or until engine has been allowed to cool for two minutes after running. Replace gasoline cap securely and wipe off any spilled gasoline before starting the engine as it may cause a fire or explosion.
5. Disengage the self-propelled mechanism or drive clutch on units so equipped before starting the engine.
6. The blade control handle is a safety device. Never attempt to bypass its operation. Doing so makes the safety device inoperative and may result in personal injury through contact with the rotating blade. The blade control handle must operate easily in both directions.
7. Never attempt to make a wheel or cutting height adjustment while the engine is running.
8. Never operate the equipment in wet grass. Always be sure of your footing. A slip and fall can cause serious personal injury. Keep a firm hold on the handle and walk, never run. Mow only in daylight or in good artificial light.

9. For your safety, use the slope gauge included as part of this manual to measure slopes before operating this unit on a sloped or hilly area. If the slope is greater than 15° as shown on the slope gauge, do not operate this unit on that area or serious injury could result.



### OPERATION

1. Do not change the engine governor settings or overspeed the engine. Excessive engine speeds are dangerous.
2. Do not put hands or feet near or under rotating parts. Keep clear of the discharge opening at all times as the rotating blade can cause injury.
3. Stop the blade when crossing gravel drives, walks or roads.
4. After striking a foreign object, stop the engine, remove the wire from the spark plug, and thoroughly inspect the mower for any damage. Repair the damage before restarting and operating the mower.
5. If the equipment should start to vibrate abnormally, stop the engine and check immediately for the cause. Vibration is generally a warning of trouble.
6. Shut the engine off and wait until the blade comes to a complete stop before removing the grass catcher or unclogging the chute. The cutting blade continues to rotate for a few seconds after the engine is shut off. Never place any part of the body in the blade area until you are sure the blade has stopped rotating.
7. Before cleaning, repairing or inspecting, make certain the blade and all moving parts have stopped. Disconnect the spark plug wire, and keep the wire away from the spark plug to prevent accidental starting.
8. Do not run the engine indoors.
9. Mow across the face of slopes, never up-and-down. Exercise extreme caution when changing direction on slopes. Do not mow excessively steep slopes. Always be sure of your footing. A slip and fall can cause serious personal injury.
10. Never operate mower without proper guards, plates or other safety protective devices in place.
11. Do not operate this mower with the chute door open, unless the complete grass catcher or chute deflector is properly mounted on the mower.
12. Do not operate this mower with the chute door open, unless the complete grass catcher or chute deflector is properly mounted on the mower.



### MAINTENANCE AND STORAGE

1. Check the blade and engine mounting bolts at frequent intervals for proper tightness.
2. Keep all nuts, bolts, and screws tight to be sure the equipment is in safe working condition.
3. Never store the equipment with gasoline in the tank inside of a building where fumes may reach an open flame or spark. Allow the engine to cool before storing in any enclosure.
4. To reduce fire hazard, keep the engine free of grass, leaves, or excessive grease.
5. Check the grass catcher bag frequently for wear or deterioration. For safety protection, replace only with new bag meeting original equipment specifications.

# ASSEMBLY INSTRUCTIONS

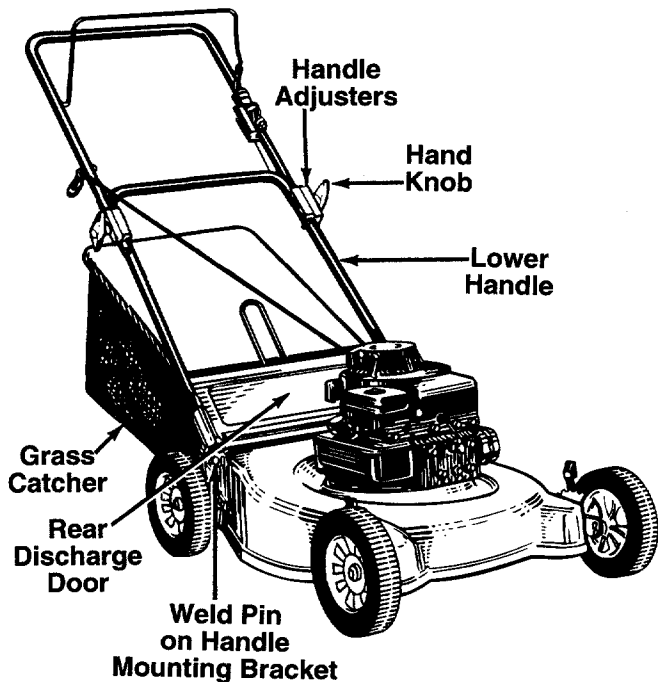

FIGURE 1.

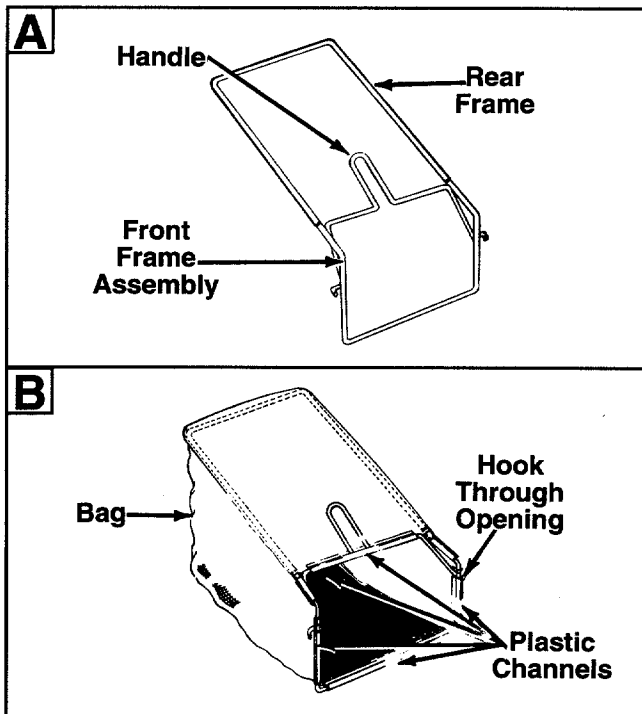

FIGURE 2.

**IMPORTANT:** This unit is shipped **WITHOUT GASOLINE** or **OIL**. After assembly, service engine with gasoline and oil as instructed in the separate engine manual packed with your unit.

**NOTE:** Reference to right or left hand side of the mower is observed from the operating position.

## TO REMOVE MOWER FROM CARTON

Remove the carton inserts. Lift the mower from the carton, or cut the corners of the carton and roll the mower out. Make certain all parts and literature have been removed from the carton before the carton is discarded.

## HOW TO SET-UP YOUR MOWER

1. Pull up and back on the lower handle. Pivot the upper handle up to raise the handle into the operating position. See figure 1.
2. The upper handle may be adjusted to three different height positions. To select desired position, align one of the three marks on the top of the lower handle adjusters with the mark on the upper handle adjusters. Tighten the hand knobs.
3. Remove the hairpin clips from the outer hole in the weld pins on the handle mounting brackets. Place the hairpin clips in the inner hole.

**NOTE:** The outer hole in the weld pin is for storage. The hairpin clip must be placed in the inner hole for operation.

## ASSEMBLING THE GRASS CATCHER

**NOTE:** Make certain the grass bag is turned right side out before assembling (warning label will be on the outside).

1. Join the rear frame and front frame assembly as shown in figure 2A. Push frames together as far as they will go.
2. Place bag over frame (black plastic side is the bottom of bag) so the handle is outside the bag. Slip openings in the side of the plastic channel on bag over the hooks on the grass catcher frame.

**NOTE:** It may be necessary to pull the edge of the fabric away from the plastic channel in order to see the opening.

3. Secure bag to frame by working the plastic channels on bag over frame as shown in figure 2B. All of the plastic channels except center top of bag attach from the outside of bag. Center top of bag attaches from the inside of bag.

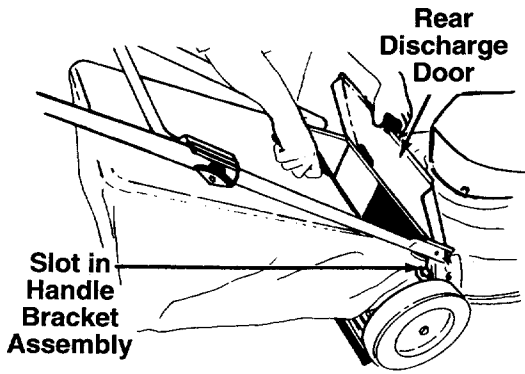

FIGURE 3.

### ATTACHING GRASS CATCHER TO MOWER

Lift the rear discharge door on the mower. Place the hooks on the grass catcher into the slots in the handle bracket assemblies. See figure 3. Release the rear discharge door.

To remove the grass catcher, lift the rear discharge door on the mower. Lift the grass catcher up, out of the slots in the handle bracket assemblies. Release the rear discharge door.



**WARNING:** Never operate the mower unless the hooks on the grass catcher are seated in the slots on the handle bracket assemblies, and the rear discharge door rests firmly against the top of the grass catcher

## CONTROLS

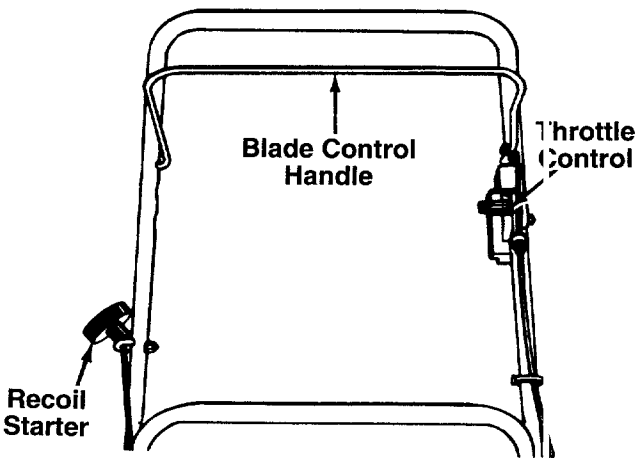

FIGURE 4.

The blade control handle is located on the upper handle of the mower. See figure 4. The blade control handle must be depressed in order to operate the unit. Release the blade control handle to stop the engine and blade.



**WARNING:** The blade will be rotating whenever the engine is running.

### THROTTLE CONTROL

The throttle control is located on the side of the upper handle or on the engine. It is used to regulate the engine speed.



**WARNING:** The throttle control cannot be used to stop the engine.

### BLADE CONTROL HANDLE



**WARNING:** This control mechanism is a safety device. Never attempt to bypass its operations.

### RECOIL STARTER

The recoil starter handle is attached to the handle. See figure 4. Stand behind the unit in the operating position to start the unit.

## OPERATION



FIGURE 5.

Keep hands and feet away from the chute area on cutting deck. See figure 5.

The operation of any lawn mower can result in foreign objects being thrown into the eyes, which can result in severe eye damage.



Always wear safety glasses or eye shields. We recommend wide vision safety mask for over spectacles or standard safety glasses.

### GAS AND OIL FILL-UP

Service the engine with gasoline and oil as instructed in the separate engine manual packed with your mower. Read instructions carefully.



**WARNING:** Never fill fuel tank indoors, with engine running or until the engine has been allowed to cool for at least two minutes after running.

### TO START ENGINE AND ENGAGE BLADE

1. Attach spark plug wire to spark plug.
2. Move throttle control lever all the way forward.
3. Prime engine as instructed in the separate engine manual.
4. Standing behind the unit, depress the blade control handle and hold it against the upper handle as shown. See figure 6.
5. Grasp the recoil starter handle and pull slowly until resistance is felt. Then pull handle rapidly to overcome compression, prevent kickback and start engine. Repeat if necessary.
6. After engine starts, move throttle control to desired engine speed.

**NOTE:** If any problems are encountered, refer to the Trouble Shooting Guide on page 10.

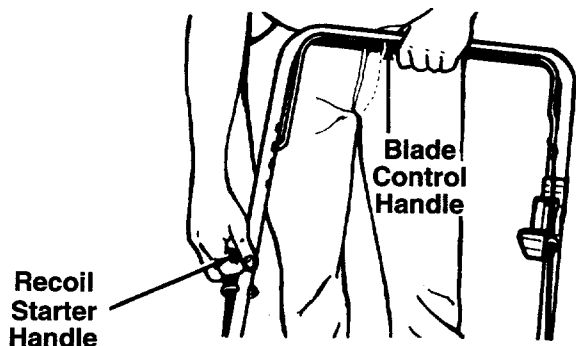

FIGURE 6.

### TO STOP ENGINE AND BLADE

1. Release the blade control handle to stop the engine and blade.



**WARNING:** The blade continues to rotate for a few seconds after the engine is shut off.

2. Disconnect the spark plug wire and ground it against the engine to prevent accidental starting while equipment is unattended.

### USING YOUR ROTARY MOWER



**WARNING:** Never operate your unit without either the rear deflector or entire grass catcher assembly in place.

Be sure that lawn is clear of stones, sticks, wire, or other objects which could damage lawn mower or engine. Such objects could be accidentally thrown by the mower in any direction and cause serious personal injury to the operator and others.

For the best results, do not cut wet grass because it tends to stick to the underside of the mower, preventing proper discharge of grass clippings, and could cause you to slip and fall. New grass, thick grass or wet grass may require a narrower cut. Blade speed should be adjusted to the condition of the lawn.

**For a healthy lawn, never cut more than one-third off the total length of the grass at any one cutting.** Lawn should be cut in the fall as long as there is growth.

This mower is designed to be operated at full throttle to give you the best cut and do the most effective job of bagging the cut grass.



**WARNING:** If you strike a foreign object, stop the engine. Remove wire from spark plug, thoroughly inspect the mower for any damage, and repair the damage before restarting and operating the mower. Extensive vibration of the mower during operation is an indication of damage. The unit should be promptly inspected and repaired.

### USING YOUR MULCHER

(Mulching Kit is Optional Equipment)

For effective mulching, do not cut wet grass because it tends to stick to the underside of the deck, preventing proper mulching of grass clippings. New or thick grass may require a narrower cut. The ground speed should be adjusted to the condition of the lawn. If mowing has been delayed and the grass has been allowed to grow in excess of 4", mulching is not recommended. Mow using the grass bag to reduce the grass height to 3-1/4" maximum before mulching. Never cut more than one-third off the total length of the grass at any one cutting.

To remove the mulching kit, simply lift the rear discharge door and remove the mulching baffle plug (Ref. No. 52 on page 8). Then attach the grass catcher.

## ADJUSTMENTS



**WARNING:** Do not at any time make any adjustment to lawn mower without first stopping engine and disconnecting spark plug wire.

## CUTTING HEIGHT ADJUSTMENT

An adjusting plate and thumb lever at each wheel position provides cutting height adjustment. Each adjusting plate has nine height positions. Height of cut will be changed when the thumb lever is moved from one hole to another. Simply depress the lever towards wheel and move wheel and lever assembly to desired position. All wheels must be placed in the same relative position. See figure 7.

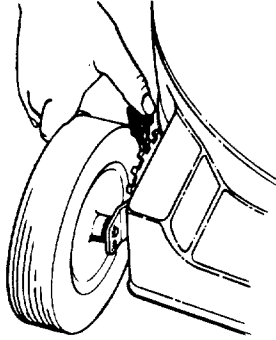

FIGURE 7.

## THROTTLE CONTROL ADJUSTMENT

If the throttle control needs adjustment or if it has been replaced, adjust as follows.

1. Remove the screw shown in figure 8. Remove the cable clamp from the cable.
2. Push the throttle control lever on the handle all the way forward as far as it will go, then back it off one "click." Make certain the throttle control lever remains in this position.
3. Push the control lever on the engine as far toward the rear of the engine as it will go. Secure the cable in this position with the cable clamp and screw.

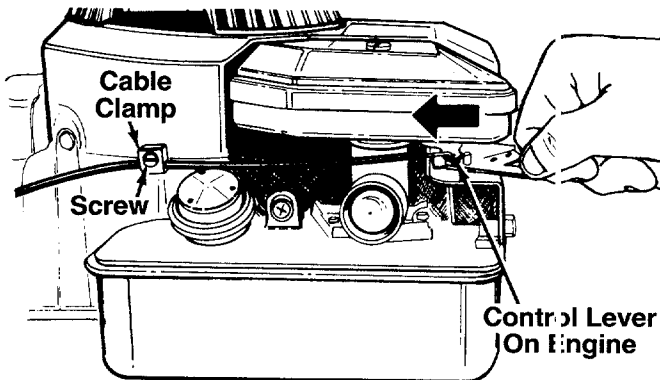

FIGURE 8.

## CARBURETOR ADJUSTMENTS



**WARNING:** If any adjustments are made to the engine while the engine is running (e.g. carburetor), keep clear of all moving parts. Be careful of heated surfaces and muffler.

Minor carburetor adjustments may be required to compensate for differences in fuel, temperature, altitude and load. To adjust carburetor, refer to the separate engine manual packed with your mower.

**NOTE:** A dirty air cleaner will cause an engine to run rough. Be certain air cleaner is clean and attached to the carburetor before adjusting carburetor. Refer to the separate engine manual.

## LUBRICATION



**WARNING:** Always stop engine and disconnect spark plug wire before cleaning, lubricating or doing any kind of work on lawn mower.

**Blade Control**—Lubricate the pivot points on the blade control handle and the brake cable at least once a season with light oil. See figure 9. The blade control must operate freely in both directions.

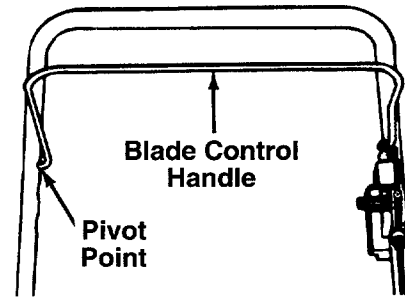

FIGURE 9.

**Rear Discharge Door**—The torsion springs and pivot points should be lubricated periodically with light oil to prevent any rust or binding. Door must work freely.

**Wheels**—The wheels require no lubrication. However, if the wheels are removed for any reason, lubricate the surface of the axle bolt and the inner surface of the wheel with light oil. A 4 oz. plastic bottle of light oil lubricant is available. Order part number 737-0170. Engine oil may also be used.

**Engine**—Follow engine manual for lubrication instructions.

## MAINTENANCE



**WARNING:** Be sure to disconnect and ground the spark plug wire before performing any repairs or maintenance.

**NOTE:** When tipping the unit, empty the fuel tank and keep engine spark plug side up.

## TROUBLE SHOOTING

Refer to page 10 of this manual for trouble shooting information.

## CUTTING BLADE

When removing the cutting blade for sharpening or replacement, protect hands by using heavy gloves or a rag to grasp the cutting blade. Remove the bolt and bell washer which hold the blade and adapter to the engine crankshaft. Remove the blade and adapter from the crankshaft.

If the blade or blade adapter needs replacing, remove the two small bolts, lock washers and nuts which hold the blade to the adapter.



**WARNING: Periodically inspect the blade adapter for cracks, especially if you strike a foreign object. Replace when necessary.**

When sharpening the blade, follow the original angle of grind as a guide. It is extremely important that each cutting edge receives an equal amount of grinding to prevent an unbalanced blade. An unbalanced blade will cause excessive vibration when rotating at high speeds, may cause damage to the mower and could break, causing personal injury.

It is recommended that the blade always be removed from the adapter for the best test of balance.

The blade can be tested by balancing it on a round shaft screwdriver. Remove metal from the heavy side until it balances evenly.

Before reassembling the blade and the blade adapter to the unit, lubricate the engine crankshaft and the inner surface of the blade adapter with light oil. Lubricating the bolt holes, bolts and inner surface of the nuts with light oil is also recommended. A 4 oz. plastic bottle of light oil lubricant is available. Order part number 737-0170. Engine oil may also be used.

When replacing the blade, be sure to install the blade with the side of the blade marked "Bottom" (or with part number) facing the ground when the mower is in the operating position.

### Blade Mounting Torque

Center Bolt: 450 in. lbs. min., 600 in. lbs. max.

Blade Adapter Bolts: 200 in. lbs. min., 350 in. lbs. max.

To insure safe operation of your unit, **all** nuts and bolts must be checked periodically for correct tightness.

## DECK

The underside of the mower deck should be cleaned after each use to prevent a buildup of grass clippings, leaves, dirt or other matter. If this debris is allowed to accumulate, it will invite rust and corrosion, and may cause an uneven discharge of grass clippings at the next cutting.

The deck may be cleaned by tilting the mower and scraping clean with a suitable tool (make certain the spark plug wire is disconnected).

## ENGINE

**Refer to the separate engine manual for engine maintenance instructions.**

Maintain **engine** oil as instructed in the separate engine manual packed with your unit. Read and follow instructions carefully.

Service **air cleaner** every 25 hours under normal conditions. Clean every few hours under extremely dusty conditions. Poor engine performance and flooding usually indicates that the air cleaner should be serviced. To service the air cleaner, refer to the separate engine manual packed with your unit.

The **spark plug** should be cleaned and the gap reset once a season. Spark plug replacement is recommended at the start of each mowing season; check engine manual for correct plug type and gap specifications.

**Clean the engine** regularly with a cloth or brush. Keep the cooling system (blower housing area) clean to permit proper air circulation which is essential to engine performance and life. Be certain to remove all grass, dirt and combustible debris from muffler area.

---

## OFF-SEASON STORAGE

---

The following steps should be taken to prepare lawn mower for storage.

1. Clean and lubricate mower thoroughly as described in the lubrication instructions.
2. Refer to engine manual for correct engine storage instructions.
3. Coat mower's cutting blade with chassis grease to prevent rusting.
4. Store mower in a dry, clean area. Do not store next to corrosive materials, such as fertilizer.

**NOTE:** *When storing any type of power equipment in an unventilated or metal storage shed, care should be taken to rust-proof the equipment. Using a light oil or silicone, coat the equipment, especially cables and all moving parts.*

---

## MULCHING KIT AVAILABLE

---

Mulching Kit model 190-099 is available as optional equipment for the mower shown in this manual. The special high lift mulching blade and baffles will pulverize the grass clippings, making it unnecessary to bag the grass.

# Model 380R

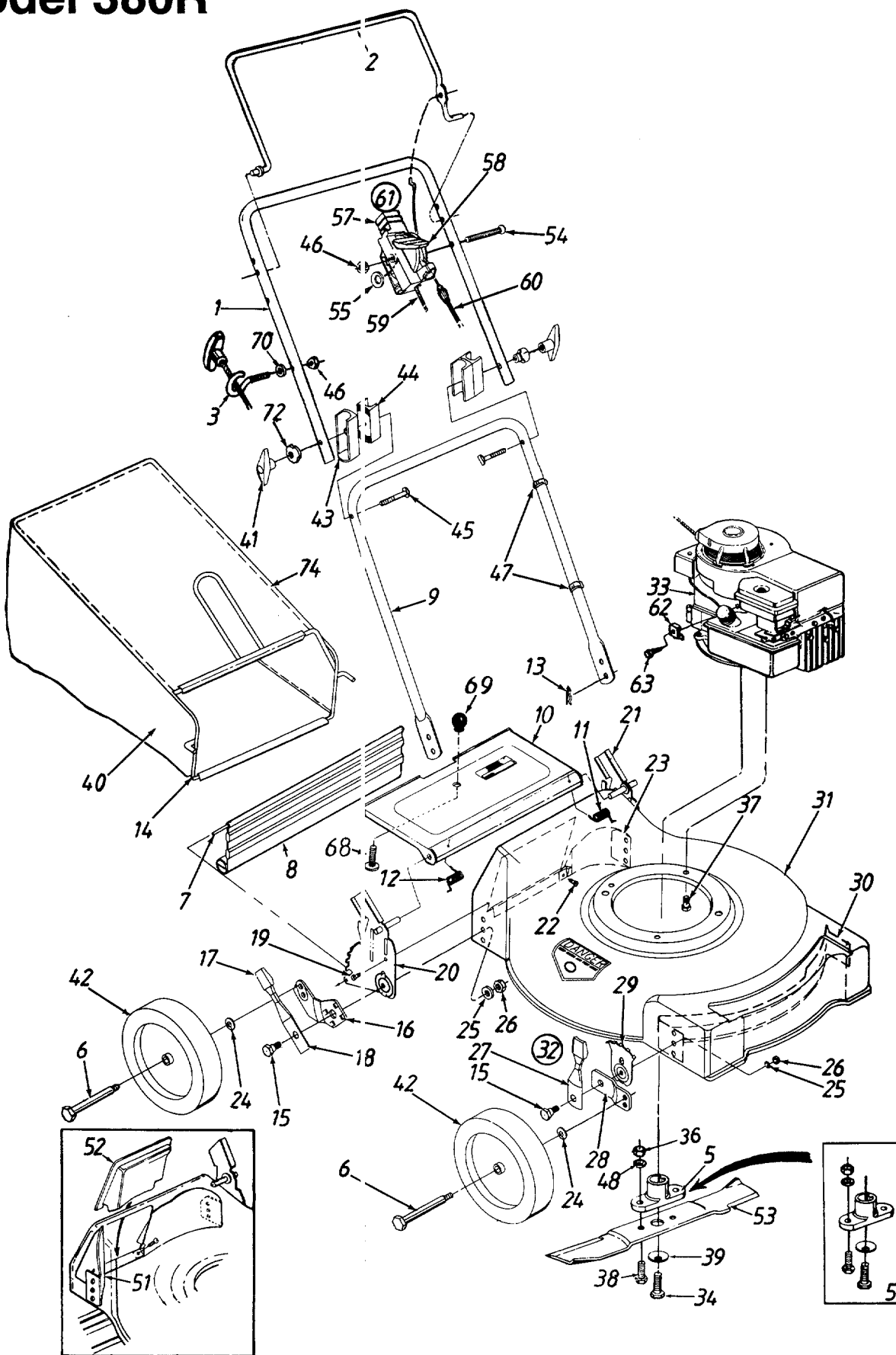



# Model 380R

## PARTS LIST FOR MODEL 380R ROTARY MOWER

REF. NO.	PART NO.	CODE	DESCRIPTION	REF. NO.	PART NO.	CODE	DESCRIPTION
1	749-0886	N	Upper Handle	33	—		Engine
2	747-0824		Control Handle	34	710-1044		Hex Bolt 3/8-24 x 1.5" Lg.
3	710-1239	N	Rope Guide	36	712-0241		Hex Nut 3/8-24 Thd.
5	753-0484		Blade Adapter Kit	37	710-0654A		Hex L-Wash. Scr. 3/8-16 x 1" Lg.
6	738-0102		Axle Bolt				Hex Bolt 3/8-24 x 1" Lg.
7	732-0712	N	Rear Flap Wire	38	710-1055		Bell-Wash. .396" I.D. x 1.14"
8	731-1261	N	Rear Flap	39	736-0452		Grass Bag
9	749-0885	N	Lower Handle	40	764-0446	N	Plastic Knob
10	782-7025	N	Chute Door	41	720-0241		Wheel Ass'y. Comp.
11	732-0677		Door Spring—L.H.	42	734-1609	N	Upper Handle Insulator
12	732-0678		Door Spring—R.H.	43	731-1268	N	Lower Handle Insulator
13	714-0104		Hairpin Clip	44	731-1267	N	Carriage Bolt 5/16-18 x 3" Lg.
14	764-0326		Front Catcher Frame	45	710-0450		Hex Top L-Nut 1/4-20 Thd.
15	738-0507B		Shld. Bolt .5" Dia. x .434"	46	712-0324		Cable Tie
16	14765		Pivot Bar—R.H.	47	726-0240		L-Wash. 3/8" I.D.*
	14766		Pivot Bar—L.H. (Not Shown)	48	736-0169		Mulching Baffle—R.R. (Optional)
17	720-0190		Spring Lever Knob	51	782-5004	N	Mulching Baffle Plug (Optional)
18	732-0417A		Spring Lever	52	782-5007	N	19" Blade
19	710-0892		Hex L-Wash. Hd. AB-Tap Scr. 1/4 x .62" Lg.	53	742-0519	N	19" Mulching Blade (Optional)
					742-0577	N	Oval C-Sunk Mach.-Scr.
20	682-0514	N	Handle Brkt. Ass'y.—R.H.	54	710-0605		Spr. Wash. .66" I.D.
21	682-0513	N	Handle Brkt. Ass'y.—L.H.	55	736-0501		Throttle Body
22	710-1017		Torx. Mach. AB-Tap Scr. 1/4 x .62" Lg.	57	746-0875		Throttle Lever
23	782-5026	N	Rear Baffle	58	746-0842		Throttle Control Wire—51"
24	736-0105		Bell-Wash. .38" I.D. x .88" O.D.	59	746-0842		Control Cable—39"
25	736-0356		Bell-Wash. .39" I.D. x 1.38" O.D.	60	746-0550		Throttle Box Comp. (Incl. Ref. 54, 55, 56, 57, 58, 59, 60)
26	712-0798		Hex Nut 3/8-16 Thd.*	61	811-00185		Cable Clamp (420R)
27	14832		Spring Lever Ass'y. w/Knob	62	751-0568		Hex Self-Tap Scr. #10-32 x .62"
28	15262B		Pivot Bar	63	710-1237		Truss Scr. #10-24 x .38" Lg.
29	15261A		Height Adj. Plate	68	710-0192		Knob
30	782-5025	N	Front Baffle	69	720-0275		Spr. Wash. 1/4" I.D.
31	782-0054	N	19" Deck	70	736-0175		Saddle Washer
32	14578		Height Adj. Ass'y. Comp.—R.H.	72	736-0451		Rear Catcher Frame
	14579		Height Adj. Ass'y. Comp.—L.H. (Not Shown)	74	764-0325		

\*For faster service obtain standard nuts, bolts and washers locally. If these items cannot be obtained locally, order by part number and size as shown on parts list.

**CODE: N** notates a new part (not previously existing).

**NOTE:** Specifications subject to change without notice or obligation.

NOTE: The engine is not under warranty by the mower manufacturer. . . If repairs or service is needed on the engine, please contact your nearest authorized engine service outlet. Check the "Yellow Pages" of your telephone book under "Engines—Gasoline."



**NOTE:** The use of any accessory on this Rotary Mower other than those manufactured by the mower manufacturer is **not** recommended.



**WARNING: DO NOT** operate the mower without the entire grass catcher or rear discharge door in place. **DO NOT** operate the mower without the protective shield on the rear of the deck in place.

**NOTE:** Under normal usage bag material is subject to wear and should be checked periodically. Be sure any replacement bag complies with the mower manufacturer's recommendations.

# TROUBLE SHOOTING GUIDE

Trouble	Possible Cause(s)	Corrective Action
Engine fails to start	<ol style="list-style-type: none"> <li>1. Blade control handle disengaged.</li> <li>2. Spark plug wire disconnected.</li> <li>3. Throttle control lever not in START position.</li> <li>4. Fuel tank empty, or stale fuel.</li> <li>5. Faulty spark plug.</li> <li>6. Engine flooded.</li> </ol>	<ol style="list-style-type: none"> <li>1. Engage blade control handle.</li> <li>2. Connect wire to spark plug.</li> <li>3. Move throttle lever to START position.</li> <li>4. Fill tank with clean, fresh gasoline.</li> <li>5. Clean, adjust gap or replace.</li> <li>6. Remove spark plug, dry the plug, and crank engine with plug removed and throttle in off position. Replace spark plug, connect wire and resume starting procedures.</li> </ol>
Engine runs erratic	<ol style="list-style-type: none"> <li>1. Unit running in START position.</li> <li>2. Spark plug wire loose.</li> <li>3. Stale fuel.</li> <li>4. Vent in gas cap plugged.</li> <li>5. Water or dirt in fuel system.</li> <li>6. Dirty air cleaner.</li> <li>7. Carburetor out of adjustment.</li> </ol>	<ol style="list-style-type: none"> <li>1. Move throttle lever to FAST position.</li> <li>2. Connect and tighten spark plug wire.</li> <li>3. Fill tank with clean, fresh gasoline.</li> <li>4. Clear vent.</li> <li>5. Drain fuel tank. Refill with fresh fuel.</li> <li>6. Clean air cleaner.†</li> <li>7. Adjust carburetor.†</li> </ol>
Engine overheats	<ol style="list-style-type: none"> <li>1. Engine oil level low.</li> <li>2. Air flow restricted.</li> <li>3. Carburetor not adjusted properly.</li> </ol>	<ol style="list-style-type: none"> <li>1. Fill crankcase with proper oil.</li> <li>2. Remove blower housing and clean.†</li> <li>3. Adjust carburetor.†</li> </ol>
Occasional skip (hesitates) at high speed	<ol style="list-style-type: none"> <li>1. Spark plug gap too close.</li> <li>2. Carburetor idle mixture adjustment improperly set.</li> </ol>	<ol style="list-style-type: none"> <li>1. Adjust gap to .030"</li> <li>2. Adjust carburetor.†</li> </ol>
Idles poorly	<ol style="list-style-type: none"> <li>1. Spark plug fouled, faulty or gap too wide.</li> <li>2. Carburetor improperly adjusted.</li> <li>3. Dirty air cleaner.</li> </ol>	<ol style="list-style-type: none"> <li>1. Reset gap to .030" or replace spark plug.</li> <li>2. Adjust carburetor.†</li> <li>3. Clean air cleaner.†</li> </ol>
Excessive vibration	<ol style="list-style-type: none"> <li>1. Cutting blade loose or unbalanced.</li> <li>2. Bent cutting blade.</li> </ol>	<ol style="list-style-type: none"> <li>1. Tighten blade and adapter. Balance blade.</li> <li>2. Replace blade.</li> </ol>
Mower will not discharge grass	<ol style="list-style-type: none"> <li>1. Engine speed too low.</li> <li>2. Wet grass.</li> <li>3. Excessively high grass.</li> </ol>	<ol style="list-style-type: none"> <li>1. Set throttle between 3/4 and full throttle.</li> <li>2. Do not mow when grass is wet; wait until later to cut.</li> <li>3. Mow once at a high cutting height, then mow again at desired height or make a narrower cutting swath (1/2 width).</li> </ol>
Uneven cut	<ol style="list-style-type: none"> <li>1. Wheels not positioned correctly.</li> <li>2. Dull blade.</li> </ol>	<ol style="list-style-type: none"> <li>1. Place all four wheels in same height position.</li> <li>2. Sharpen or replace blade.</li> </ol>

†Refer to separate engine manual packed with your unit.

Note: For repairs beyond the minor adjustments listed above, contact your local authorized service dealer.

# SLOPE GAUGE

(Keep this sheet in a safe place for future reference.)

USE THIS SHEET AS A GUIDE TO DETERMINE SLOPES WHERE YOU MAY NOT OPERATE SAFELY.

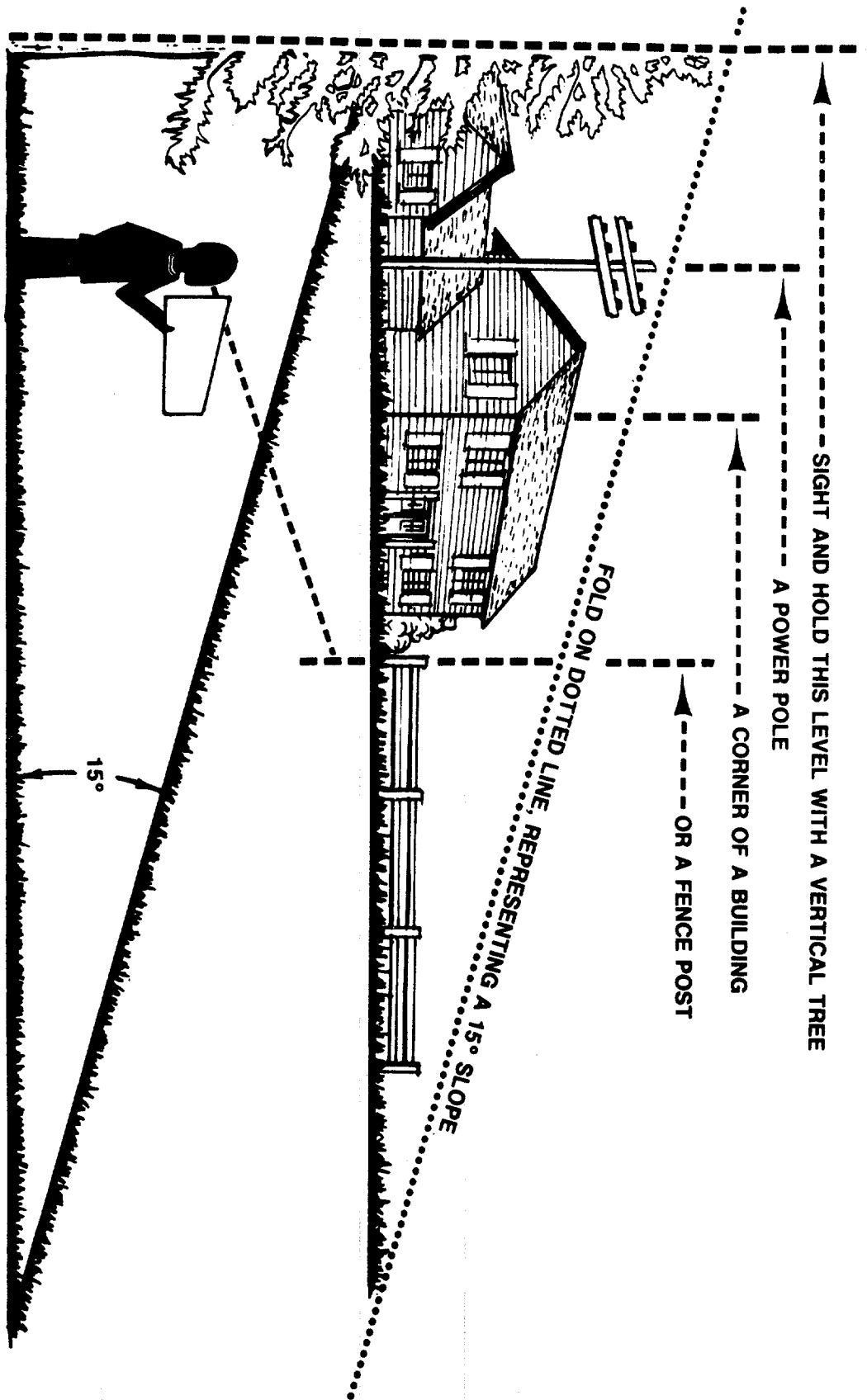

Do not mow on inclines with a slope in excess of 15 degrees (a rise of approximately 2-1/2 feet every 10 feet). A riding mower could overturn and cause serious injury. If operating a walk-behind mower on such a slope, it is extremely difficult to maintain your footing and you could slip, resulting in serious injury.

Operate RIDING mowers up and down slopes, never across the face of slopes.  
Operate WALK-BEHIND mowers across the face of slopes, never up and down slopes.

***FOR REPLACEMENT PARTS, CONTACT:***  
**SERVICE DEPARTMENT • P.O. BOX 360900 • CLEVELAND, OHIO 44136**